

Contribution from the Department of Chemistry, The University of Chicago, Chicago, Illinois 60637,
Department of Chemistry, The University of Nottingham, Nottingham NG7 2RD, U.K.,
and Rutherford Appleton Laboratory, Didcot OX11 0QX, U.K.

Oxygen Fluorides, Non-Metal Halides, van der Waals Molecules, and Related Species: A Linking Theoretical Thread

JEREMY K. BURDETT,*^{1a,b} NICHOLAS J. LAWRENCE,^{1c} and JAMES J. TURNER^{1d}

Received September 15, 1983

Two problems are tackled in this paper: (i) site preferences in XAB and A₂X₂ systems as a function of electronegativity; (ii) the variation in AX, AA, and AB bond strengths as a function of the electronegativity of X. It is pointed out that the very long noble gas-diatom distances in van der Waals molecules (e.g., in Ar...ClF) are just an extreme case of the long OF distances in O₂F₂, O₂F, and related species, induced by a terminal atom of high electronegativity. The structures of these molecules are viewed in terms of a simple three-center orbital problem. The bonding characteristics of these orbitals are shown to be dependent upon the difference in (i) orbital ionization potentials of the terminal atoms of such a unit and (ii) the overlap integrals between the central and terminal atom orbitals. A coherent scheme is presented that is able to rationalize the unusually short and long distances found in XAB systems (X = noble gas, halogen, hydrogen; A, B = halogen, carbon, nitrogen, oxygen, sulfur). The new model is more versatile than the (p-π*)σ bonding model originally suggested to rationalize the structure of O₂F₂.

Introduction

Chemists are quite well provided with simple molecular orbital approaches with which to tackle the stereochemistry of simple main-group molecules. Whether an AX₃ system, for example, is planar, pyramidal, or T-shaped and how its geometry is dependent on the nature of X and the electronic configuration may be viewed in a variety of ways (see ref 2-5 for examples). An area that has received somewhat less attention is the question of the stability of one particular linkage isomer over another and the often dramatic differences in bond lengths in two alternative structures when they are both available for study. In this paper we study theoretically a subset of this problem, namely the structures of XAB and A₂X₂ systems (X = halogen, noble gas, H; A, B = C, O, N, S, halogen). The nub of this structural problem may be briefly summarized by describing the salient features of the geometries and interatomic distances found for some of the molecules (Table I).

O₂F₂ and O₂F have OO force constants indicative of a bond order close to that in O₂ itself,^{6,7} and the microwave determination⁸ of the structure of O₂F₂ (1) shows an OO distance

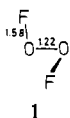

very close to that for the oxygen molecule. The OF bond in O₂F₂ is very long (1.58 Å) compared to that in OF₂ (1.41 Å), and this is reflected⁹ in the high fluorinating power of O₂F₂.

However, isostructural H₂O₂ has¹⁰ an OO distance of 1.48 Å suggestive of a bond order of around unity, and the OH distance is similar to that in H₂O. XNO species follow a very similar trend, the NF and NO bonds in FNO being unusually long and short, respectively.¹¹ Significant but less pronounced anomalies are also seen for BrNO and ClNO.¹² In HNO the NH distance is not unusual^{13,14} and is comparable to that in NH₃. By way of contrast, the bond lengths in FCO are more nearly normal.¹⁵ Vibrational studies show force constants that are very similar to those in carbonyl fluoride. HCO on the other hand¹⁵ has a long CH but short CO bond. Interestingly, and surprisingly, whereas infrared data show ClOO to have a weak ClO and strong OO bond,^{16,17} just like the fluorine analogue, ClOOCl appears to be a weakly bound dimer, perhaps with a geometry akin to that of (NO)₂ (2).¹⁸ Similar

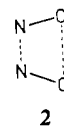

unusual interatomic distances are found for the S₂(halogen)₂ species,^{19,20} which all have the O₂F₂ structure. Longer than normal S-halogen and shorter than expected S-S linkages are found. S₂F₂ is also found as the 1,1 isomer 3 containing a



three-coordinate sulfur atom, as in the isoelectronic NF₃ molecule. Both in this isomer and in OSX₂ (X = F, Cl, Br)

- (1) (a) Fellow of the Alfred P. Sloan Foundation and Camille and Henry Dreyfus Teacher-Scholar. (b) University of Chicago. (c) Rutherford Appleton Laboratory. (d) University of Nottingham.
- (2) Walsh, A. D. *J. Chem. Soc.* **1953**, 2260, 2266, 2288, 2296, 2301, 2306.
- (3) Gillespie, R. J. "Molecular Geometry"; Van Nostrand-Reinhold: London, 1972.
- (4) Gimarc, B. M. "Molecular Structure and Bonding"; Academic Press: New York, 1979.
- (5) Burdett, J. K. "Molecular Shapes"; Wiley: New York, 1980.
- (6) We note however the problems associated with the vibrational potential function of O₂F₂: (a) Burdett, J. K.; Gardiner, D. J.; Turner, J. J.; Spratley, R. D.; Tchir, P. *J. Chem. Soc., Dalton Trans.* **1973**, 1928. (b) Jacox, M. E. *J. Mol. Spectrosc.* **1980**, 84, 74.
- (7) Noble, P. N.; Pimentel, G. C. *J. Chem. Phys.* **1966**, 44, 3641.
- (8) Jackson, R. H. *J. Chem. Soc.* **1962**, 4585.
- (9) (a) Streng, A. G. *Chem. Rev.* **1963**, 63, 607. (b) Turner, J. J. In "Comprehensive Inorganic Chemistry"; Bailar, J. C.; Emeleus, H. J.; Nyholm, R. S.; Trotman-Dickenson, A. F. Eds.; Pergamon Press: London, 1973.

- (10) Redington, R. L.; Olsen, W. B.; Cross, P. C. *J. Chem. Phys.* **1962**, 36, 7311.
- (11) (a) Stephensen, C. V.; Jones, E. A. *J. Chem. Phys.* **1952**, 20, 135. (b) Jones, L. H.; Asprey, L. B.; Ryan, R. R. *Ibid.* **1967**, 47, 3371; **1968**, 49, 581. (c) Sawodny, W.; Fadini, A.; Ballein, K. *Spectrochim. Acta* **1965**, 21, 995.
- (12) Ketelaar, J. A. A.; Palmer, K. J. *J. Am. Chem. Soc.* **1937**, 59, 2629.
- (13) Brown, H. W.; Pimentel, G. C. *J. Chem. Phys.* **1958**, 29, 883.
- (14) Milligan, D. E.; Jacox, M. E.; Charles, S. W.; Pimentel, G. C. *J. Chem. Phys.* **1962**, 37, 2302.
- (15) Shirk, J. S.; Pimentel, G. C. *J. Am. Chem. Soc.* **1968**, 90, 3349.
- (16) Rockkind, M. M.; Pimentel, G. C. *J. Chem. Phys.* **1967**, 46, 4481.
- (17) (a) Alcock, W. G.; Pimentel, G. C. *J. Chem. Phys.* **1968**, 48, 2373. (b) Arkell, A.; Schwager, I. *J. Am. Chem. Soc.* **1967**, 89, 5999. (c) Rockkind, M. M.; Pimentel, G. C. *J. Chem. Phys.* **1965**, 42, 1361.
- (18) Guillard, W.; Hunter, C. E. *J. Chem. Phys.* **1969**, 50, 3516.
- (19) Kuczowski, R. L. *J. Am. Chem. Soc.* **1964**, 86, 3617.
- (20) (a) Hirota, E. *Bull. Chem. Soc. Jpn.* **1958**, 31, 130. (b) Kniep, R.; Korte, L.; Mootz, D. *Z. Naturforsch., B: Anorg. Chem., Org. Chem.* **1983**, 38B, 1.

Table I. Selected Bond Lengths and Force Constants for Molecules of Interest

	bond length, Å			force const, mdyn/Å			ref
	r _{AH}	r _{AX}	r _{AB}	f _{AH}	f _{AX}	f _{AB}	
O ₂			1.21			11.93	d
HOH	0.96			7.66			
FOF		1.41			3.95		
ClOCl					2.75		52b
HOO			6.46		6.2		64a
FOO				1.32	10.50		7
ClOO				1.29	9.7		52
BrOO					1487 ^k		61
HOOH	0.95	1.48	7.4		4.6		10
FOOF		1.58	1.22	1.36	10.00		6, 8
ClOOF							16, 17
HSSH	1.33	2.05					b
FSSF	1.64	1.89			3.72		19
ClSSCl	2.07	1.97					19, 20
BrSSBr	2.24	1.98					19, 20
HSSH					2.58		b
SSF ₂	1.60	1.86		4.50	19		
OSF ₂	1.58	1.41					21
FSF	1.59						
ClSCl	2.00			2.68			
SN					8.53		g
FSN				2.87	10.71		56
ClSN				1.38	10.10		56, c
BrSN				1.29	9.88		56
NO		1.15			15.5		d
FNO	1.52	1.13		2.1	15.1		11
ClNO	1.98	1.14		2.1	14.8		12
HNO	1.02	1.24	7.0		10.5		13, 14
CO		1.13			18.5		d
FCO	1.34	1.18		4.53	12.85		15
F ₂ CO	1.32	1.17		4.55	12.85		a
HCO	1.15	1.18	3.32		14.1		15, 65, 66
CICO				1.5	14.3		15
FON		1.26	1.16				h
ClCN		1.63	1.16				i
BrCN	1.79	1.16					j
ClIO				320 ⁱ	776 ^l		m
IO					681 ⁿ		m
ICI		2.30		384 ⁿ			m
FCIO				2.59	6.85		33
ClCIO					5.94		34
ClO					4.66		34
Cl ₂				3.16			34
BrOBr					526 ^l		53
BrBrO					804 ^l		53
OBRO					850 ^l		53
BrO					740 ^l		53
ArNN	f	f					e
ArCIF	2.34	1.63					49
ClIBr ⁻	2.91	2.51					62b,c
BrII ⁻	2.91	2.78					62b,c
IBr		2.52					68a
ICl		2.30					68a
I ₂		2.67					68a

^a Overend, J.; Scherer, J. R. *J. Chem. Phys.* **1960**, *32*, 1296.
^b Stevenson, D. P.; Beach, J. Y. *J. Am. Chem. Soc.* **1938**, *60*, 2872.
^c Beppu, T.; Hirota, E.; Morino, Y. *J. Mol. Spectrosc.* **1970**, *36*, 386.
^d Herzberg, G. "Spectra of Diatomic Molecules"; Van Nostrand-Reinhold: New York, 1950.
^e Henderson, G.; Ewing, G. E. *Mol. Phys.* **1974**, *27*, 903.
^f NN distance is close to that for N₂ itself with a long ArN distance.
^g Glemser, O.; Müller, A.; Böhrer, D.; Krebs, B. *Z. Anorg. Allg. Chem.* **1968**, *357*, 184.
^h Tyler, J. K.; Sheridan, J. *Trans. Faraday Soc.* **1963**, *59*, 2661.
ⁱ Lafferty, W. J.; Lide, D. R.; Toth, R. A. *J. Chem. Phys.* **1965**, *43*, 2063.
^j Townes, C. H.; Halden, A. N.; Merritt, F. R. *Phys. Rev.* **1948**, *74*, 1113.
^k For O₂Br vibrational frequency data only are available (frequency in cm⁻¹). See ref 61. For comparison, ν(OO) in FOO and ClOO is 1494 and 1441 cm⁻¹, respectively.
^l For some of these species, vibrational frequencies only are available (frequencies in cm⁻¹). See ref 53.
^m Downs, A. J.; Adams, C. J. In Reference 9b.
ⁿ ω_e values.

and OSeF₂ with a similar arrangement,²¹ the SX distances are similar to those in SX₂.

The unusual bond lengths and vibrational force constants described above and tabulated in Table I are generally associated with the presence of a terminal atom with a higher electronegativity than the other atoms in the molecule. Taken to its extreme limit, we could view the very long distances between noble gas atoms and diatomic molecules in van der Waals molecules²² as being of similar origin. The noble gases, as a group, have the highest electronegativities of all the elements (Table II). We have briefly mentioned this analogy in a recent study on van der Waals molecules themselves²³ using simple molecular orbital ideas. Similar structural effects are seen in the polyhalide anions XAA⁻ and XAB⁻. Much of the experimental data on these systems derive from the use of less conventional methods such as matrix isolation and, to a lesser extent, from the study of molecules in cooled supersonic jets and of reactions in crossed molecular beams.

Existing Bonding Models

We begin by pointing out that some of these molecules pose a real problem for even the very best numerical calculations possible at this time. The discrepancies between observed and computed bond lengths found²⁴ in an extremely high-quality calculation on O₂F₂ were unprecedented for this level of calculation. (The error in the O distance was 0.18 Å.) Numerical studies on this molecule have posed problems since the early explorations of Pople,²⁵ and many difficulties in dealing with peroxides and especially fluoroperoxides have been recently identified.²⁶ Within this background we briefly review existing qualitative models, with an eye to presenting one of our own. While obviously not capable of generating accurate geometries we hope it will be of use in tying together some of the structural observations in this area. Pauling suggested²⁷ a significant contribution from the resonance structure X⁻NO⁺ for the XNO series. This will lengthen the NX and shorten the NO bonds. Along the same lines the main difference between O₂F₂ and H₂O₂ then lies in the larger contribution to the structure from the canonical forms **5** and **6** compared to **4** for an electronegative X atom. Such an approach however

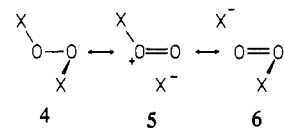

is more difficult to apply to free radicals such as FOO and does not immediately resolve the rather weak dimer structure of Cl₂O₂. Similar problems arise from Linnett's NPSO approach, which basically uses²⁸ the observed geometries to identify the prevalent double-quartet structure in a post hoc ergo propter hoc fashion. An orbital approach to the problem was suggested⁸ to Jackson in a communication by Lipscomb and has since been extended by Spratley, Pimental,²⁹ and

- (21) (a) Ferguson, R. C. *J. Am. Chem. Soc.* **1954**, *76*, 850. (b) Palmer, K. *J. Ibid.* **1938**, *60*, 2360. (c) Stevenson, D. P.; Cooley, R. A. *Ibid.* **1940**, *62*, 2477.
(22) (a) Klemperer, W. *Ber. Bunsenges. Phys. Chem.* **1974**, *78*, 128. (b) Levy, D. *Adv. Chem. Phys.* **1981**, *47*, 323. (c) Ewing, G. E. *Acc. Chem. Res.* **1975**, *8*, 185.
(23) Burdett, J. K. *J. Chem. Phys.* **1980**, *73*, 2825.
(24) Lucchese, R. R.; Schaefer, H. F.; Rodwell, W. R.; Radom, L. *J. Chem. Phys.* **1978**, *68*, 2507.
(25) Pople, J. A.; Beveridge, D. L. "Approximate Molecular Orbital Theory"; McGraw-Hill: New York, 1970.
(26) Cremer, D. *J. Am. Chem. Soc.* **1981**, *103*, 3619; *J. Chem. Phys.* **1979**, *70*, 1898, 1911, 1928; In "The Chemistry of Functional Groups, Peroxides"; Patai, S., Ed.; Wiley: New York, 1982.
(27) Pauling, L. "The Nature of the Chemical Bond"; 3rd ed.; Cornell University Press: Ithaca, NY, 1960; p 345.
(28) Linnett, J. W. "The Electronic Structure of Molecules"; Methuen: London, 1964.
(29) Spratley, R. D.; Pimental, G. C. *J. Am. Chem. Soc.* **1966**, *88*, 2394.

Table II. Electronegativities of Some Selected Elements

	C	N	O	F	Cl	Br	I	S	Ne	Ar	Kr	Xe
Sanderson ^a	2.47	2.93	3.46	3.92	3.28	2.96	2.50	2.66	4.38	3.92	3.17	2.63
Allred-Rochow ^b	2.50	3.07	3.50	4.10	2.83	2.74	2.21	2.44	5.1 ^d	3.3 ^d	3.1 ^d	2.4 ^d
Pauling ^c	2.55	3.04	3.44	3.98	3.16	2.96	2.66	2.58			2.9	2.6
quantum defect ^e	2.51	3.00	3.50	4.00	2.70	2.39	2.19	2.42				
Mulliken ^f	1.75	2.28	3.04	3.90	2.95	2.62	2.21	2.28				
VSIP ^g	13.90	16.55	19.18	23.58	18.75	16.21*	14.32*	14.98	29.52*	21.81	19.16*	18.40*

^a Sanderson, R. T. "Inorganic Chemistry"; Van Nostrand-Reinhold: New York, 1967. ^b Allred, A. L.; Rochow, E. G. *J. Inorg. Nucl. Chem.* 1958, 5, 264. ^c Allred, A. L. *Ibid.* 1961, 17, 215. ^d Calculated by: Huheey, J. E. "Inorganic Chemistry"; Harper and Row: New York, 1978. ^e Pseudopotential quantum defect radii and electronegativities from: Bloch, A. N.; Schattemann, G. C. "Structure and Bonding in Crystals"; Navrotsky, A., O'Keefe, M., Eds., Academic Press: New York, 1981. ^f From: Pritchard, H. O.; Skinner, H. A. *Chem. Rev.* 1955, 745 (for p orbital ionization (s for H)). ^g From ref 5 and 74 except those marked with an asterisk, which are from ref 75. The values given are a weighted sum of s, p energies except those marked with an asterisk, which are scaled p orbital energies. The scaling factor is that derived by using the data for fluorine (units are eV).

others. (We call it the JLSP approach.) For example, the ground state of the oxygen molecule derives from the orbital configuration

$$KK(s\sigma)^2(s\sigma^*)^2(\pi_y)^2(\pi_x)^2(p\sigma)^2(\pi_y^*)^1(\pi_x^*)^1$$

where $s\sigma$ and $p\sigma$ denote σ orbitals directed along the figure axis (z) of the molecule and composed predominantly of contributions from the s and p orbitals, respectively, on the oxygen atoms. The premise of the JLSP scheme is that a $2p$ orbital on fluorine (or in general an X species) can overlap with one of the four lobes of a singly occupied π^* orbital of the oxygen molecule to produce a weak OF linkage (7), a

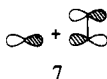

($p-\pi^*$) σ bond. The OO bond strength now depends upon the net gain or loss of electron density by this π^* orbital. The electronegative fluorine atom is not expected to be a good donor in this sense, whereas the more electropositive hydrogen atom could inject a large amount of electron density into this π^* orbital. On this scheme then the OO bond strength in H_2O_2 should be much less than that in O_2F_2 . (Since the dihedral angle is close to 90° , it is proposed that each X atom interacts with one of the orthogonal components of the degenerate π^* system of O_2).

An exactly analogous argument is applicable to the XNO series where, for NO itself, only one of the π^* orbitals is singly occupied. Hydrogen should release more density than fluorine by using this approach so that HNO should have a weaker NO bond than FNO, as found experimentally. One difficulty with this model is that, since the electronegativities (Pauling scale) of H, Br, Cl, and F are 2.2, 3.0, 3.2, and 4.0, respectively, the behavior of XNO and XOO (X = H, Br, Cl, F) should change steadily from H to F. In fact the halogen-containing species have very similar structures, whereas the hydrogen-containing species is very different. The implication of this observation is that simple electronegativity arguments are inadequate.

A further problem is that for XNO (X = Cl, Br) the X atoms should then be positively charged if the JLSP scheme is interpreted literally. However, both NQR^{30,31} and dipole moment³² studies indicate that this is not true; the halogen atoms are indeed negatively charged in these species.

The ($p-\pi^*$) σ bond approach has also been discussed with respect to the series XCO by Shirk and Pimentel.¹⁵ They conclude that the differences between the CO bond strengths in this series are much smaller than expected after the experience of the XOO and XNO series. Rather seriously the scheme predicts weak XC and strong CO linkages in an

analogous fashion to the nitrosyl and oxygenyl series for X = halogen, which are not observed.

One other feature of the JLSP scheme is that in XAB it is not immediately obvious whether the X atom will donate or withdraw electron density to or from the AB π^* orbital, a point made by Spratley and Pimentel.²⁹ More recent experimental results suggest that there are molecules where, on this scheme, electron density is moved from π^* to X. For instance, in the series ClO, FClO, and ClCO^{33,34} the ClO force constants are 4.66, 6.85, and 5.94 mdyn \AA^{-1} , respectively. The rise from ClO to XClO implies electron transfer to X and at its simplest level implies that ClO is less electronegative than X.

In spite of the simplicity and applicability of the JLSP approach, it cannot comment on other features of interest concerning these molecules such as why a given atom will lie in a central or terminal site in XAB. Below we present a molecular orbital argument that neatly accounts for atomic site preferences, takes account of some of these structural effects for all four series XAO (A = O, N, C, Cl), is supported by quantitative calculations, and does not suffer from the charge problems inherent in the JLSP approach. An important feature of the model is that it does not treat these systems as "special situations" but uses the same rules and techniques with which inorganic and organic chemists are quite familiar. We start by examining the fundamental question of atomic site preferences in such species.

Three-Center Orbitals and Site Preferences

We initially consider a very simple system, that of the interaction of three identical A-atom-located orbitals in a linear A_3 unit. These may be three $p\sigma$ or $p\pi$ orbitals (e.g., in I_3^- , N_3^-) or perhaps the three π orbitals of the allyl anion. Simple Hückel theory leads straightaway^{35,36} to two very basic results (Figure 1). (i) The stabilization energy, $2^{1/2}\beta$ for each 3c-4e bond (in the allyl anion or in I_3^- for example) is less than that, 2β , for a simple 2c-2e bond (as found in ethylene or I_2 for example). (ii) For the 3c-4e system the charges on the end atoms are higher than that on the middle atom of the trio and higher than that on the two atoms involved in simple 2c-2e bonding. The consequences of (i) in organic π systems is well-known both in terms of bond length variations and in "delocalization" energies in extended π networks.³⁵ For the triiodide ion in its symmetrical structure, the I-I distance is 2.91 \AA to be compared with 2.667 \AA in I_2 itself,³⁷ a conse-

(30) Weatherby, T. L.; Williams, Q. *J. Chem. Phys.* 1956, 25, 717.

(31) Millen, P. J.; Pannell, J. *J. Chem. Soc.* 1961, 1322.

(32) Ketelaar, J. A. A. *Recl. Trav. Chim. Pays-Bas* 1943, 62, 289.

(33) Andrews, L.; Chi, F. K.; Arkell, A. *J. Am. Chem. Soc.* 1974, 96, 1997.

(34) Chi, F. K.; Andrews, L. *J. Phys. Chem.* 1973, 77, 3062.

(35) Heilbronner, E.; Bock, H. "The HMO Model and Its Applications"; Wiley: New York, 1976.

(36) Streitwieser, A. "Molecular Orbital Theory for Organic Chemists"; Wiley: New York, 1961.

(37) Care needs to be exercised here. Depending on its environment the I-I distances in I_3^- vary from being completely symmetrical to being best described as an I_2 molecule weakly perturbed by I^- . See: Bürgi, H.-B. *Angew. Chem., Int. Ed. Engl.* 1975, 14, 460.

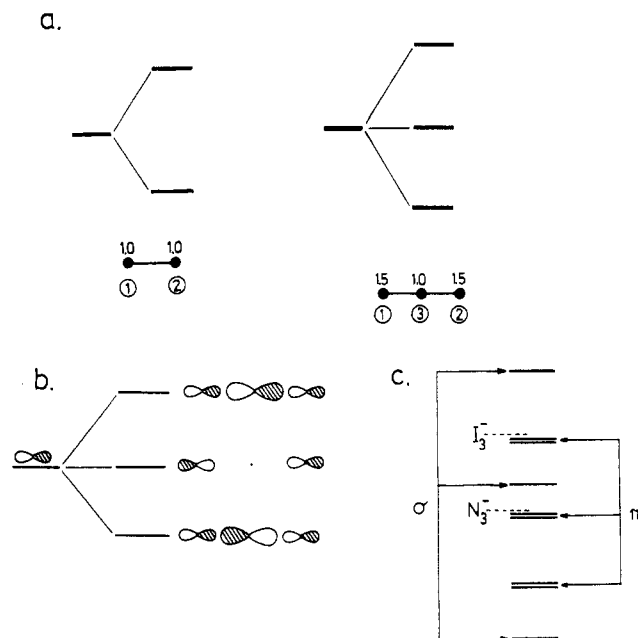

Figure 1. (a) Hückel diagrams for the π orbitals in ethylene and allyl. Also shown are the atomic electron densities for the cases of the ethylene molecule and the allyl anion. (b) Rundle and Pimentel p-only diagram for the triiodide anion. (c) Simplified σ and π three-center diagram for I_3^- (22 electrons) and N_3^- (16 electrons).

quence of the reduced stabilization energy per bond in the three-center system. There are many other examples showing a similar effect. The site preferences of mixed AX_n-X_x' ($x \leq n$) systems may be approached^{5,38} by using (ii). The most electronegative atoms of such a molecule will prefer energetically to reside at sites that in the AX_n parent carry the highest charge. This is a result well understood from both valence-bond and molecular orbital reasoning. Using the language of valence-bond theory for example we may write for the XAB molecule the canonical structures X^-A^+B and $X-A^+B^-$. These are best stabilized for electronegative X and B .

We may express this result algebraically in molecular orbital terms. The one-electron energy of a molecule may be written approximately within the extended Hückel formalism as

$$E \approx \sum_i q_i H_{ii} \quad (1)$$

where q_i is the charge associated with orbital ϕ_i given a certain number of valence electrons and H_{ii} is its valence-shell ionization energy. Let us now substitute one of the atoms of this molecule by one with different H_{ii} values (i.e., an atom of different electronegativity). The lowest energy structural possibility will be the one with the best match of $\{q_i\}$ and $\{H_{ii}\}$. For such a simple substitution this will be where the most electronegative atoms (largest negative H_{ii}) are located in those sites of largest q_i . As an example, ClF_3 or ICl_3 may be considered (8) on the Rundle-Pimentel p-orbital-only model⁵ used

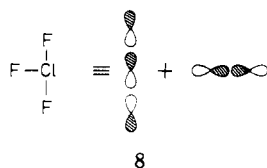

in Figure 1b for I_3^- as being constructed from two $3c-4e$ bonds

(38) There are several papers by the Hoffmann school where this technique is extensively used. For example: Chen, M. M. L.; Hoffmann, R. J. *Am. Chem. Soc.* **1976**, *98*, 1647.

("axial" ligands of the VSEPR³ trigonal bipyramid) and one $2c-2e$ bond (equatorial ligand).³⁹ The axial sites in this case carry the highest ligand charges and in $C_6H_5ICl_2$ are occupied by the electronegative Cl atoms rather than the phenyl group. In addition it is the more electronegative fluorine atoms that are the ligands in ClF_3 and the more electronegative chlorine atoms that are in the ligands in ICl_3 . The structure where the most electronegative atom of the set lies in the central position is not found, also consistent with (ii) above. A general result that is widely applicable^{40,41} is that for non-hydrides the most electronegative atoms prefer sites of low coordination number, as long as the middle orbitals of the three-center set are occupied.⁴² 9 shows the results calculated for A_3 molecules, by

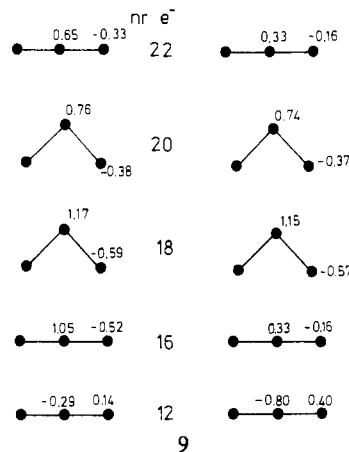

using the extended Hückel method,⁴³ as a function of the number of valence electrons. Note that 18- and 20-electron molecules are nonlinear on Walsh's scheme, and this is the geometry we have used. Two sets of numbers are presented, the first (at the left) where both s, p orbitals are used on each atom (we chose oxygen in this model study) and the second (at the right) where p orbitals only have been used. As may be seen, the general features of Figure 1 carry over to the more complex cases where the molecule is nonlinear and where sp mixing is allowed. With 12 electrons (e.g., C_3), only the lowest of the trio of three-center orbitals is occupied and the charge is highest on the central atom. With 16 electrons, now that the middle orbitals of π type are occupied, the sign of the charge distribution is reversed. As a result, although 12-electron In_2O and Ga_2O are found⁴⁴ as $InOIn$ and $GaOGa$, (and 12-electron C_2N^+ is calculated⁴⁵ to have the structure CNC^+) 16-electron N_2O is found as NNO . The location of the electronegative oxygen atom has reversed as the number of electrons has increased. We have noted elsewhere⁴⁶ a similar

- (39) Organic chemists are used to mixing localized and delocalized bonding descriptions in the same molecule. Benzene is a classic example and contains a delocalized π system and localized CC and CH σ bonds. Inorganic chemists have been more reluctant to do this, and a frequent theoretical crutch in this area has been the forcible involvement of central-atom d orbitals to treat hypervalent molecules within the localized framework. We feel this is an unnecessary complication. d orbitals are important in fine tuning the geometrical details of these molecules but not vital in understanding gross features of geometry—our major aim in this paper.
- (40) See also the rules described in: DeKock, R. L.; Gray, H. B. "Chemical Structure and Bonding"; Benjamin-Cummings: Menlo Park, CA, 1980; p 115.
- (41) This approach may be applied to solids too. See: Burdett, J. K. In "Structure and Bonding in Crystals"; Academic Press: New York, 1981; Vol. 1.
- (42) Hydrides are a little different since the hydrogen atom carries no p orbitals. We refer the reader to an orbital diagram of OH_2 for an example⁴⁵ where the largely hydrogen-located orbital that corresponds to the middle orbital of the three-center problem is unoccupied.
- (43) Hoffmann, R. *J. Chem. Phys.* **1963**, *39*, 1397.
- (44) Hinchcliffe, A. J.; Ogdan, J. S. *J. Phys. Chem.* **1973**, *77*, 2537.
- (45) Haese, N. M.; Woods, R. C. *Astrophys. J.* **1981**, *246*, L51.
- (46) Burdett, J. K. *J. Am. Chem. Soc.* **1980**, *102*, 450.

site preference reversal between 8- and 16-electron AX_2 solids with the cadmium halide structure. In the region of 13 and 14 electrons where site preference energies may not be expected to be large, CNC, CCN, NCN, and CNN are all found.⁴⁷ The results of 9 are applicable to van der Waals molecules too.⁴⁸ Thus, the $Ar \cdots ClF$ molecule contains⁴⁹ an argon atom coordinated to the least electronegative atom of the diatomic, a rule of universal validity for all the van der Waals molecules of this type known to date. Very electronegative noble gas atoms are invariably found in terminal positions (e.g., $Ar \cdots ClF$), except in compounds containing lighter and more electronegative terminal atoms (e.g., $ClXeCl$, $FKrF$, XeO_3). (Note that these species are invariably thermodynamically unstable when compared to the products of decomposition, e.g., $KrF_2 \rightarrow Kr + F_2$.)

The unstable species $ClIO$ ⁵⁰ and $FCIO$ ⁵¹ have been identified in low-temperature matrices where again the most electronegative atoms are in the terminal positions.⁵¹ The structure of OCl_2 as a gaseous molecule ($ClOCl$) presents an interesting situation since oxygen is more electronegative than chlorine on most electronegativity scales (Table II). We should therefore on our scheme expect to observe $OCICl$ (geometry 10) as the lower energy isomer. However, oxygen and chlorine

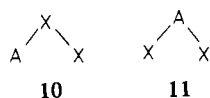

have very similar electronegativities when average values of their valence-shell ionization potentials are concerned (Table II), which are the data we should really use with eq 1. The energies of the two isomers $ClClO$ (10) and $ClOCl$ (11) are probably quite close in fact.⁵² The former may be made¹⁷ in low-temperature matrices by photolysis of "normal" $ClOCl$. For the bromine oxides, no stable gaseous molecule BrO_2 or OBr_2 exists. In matrices all four species $BrOO$, $OBrO$, $OBrBr$, and $BrOBr$ have been identified.⁵³ No information exists as to the lower energy isomer in each case. PCl_2 ⁵⁴ and NCl_2 ^{54,55} are also known in both forms, but there is no evidence yet for OFF or NFF , two species whose symmetrical isomers are well-known. This is in accord with our model since the electronegativity differences ($\Delta\chi$) on the VSIP scale of Table II are as follows: (Cl, O) 0.43; (N, Cl) 2.20; (P, Cl) 3.6; (F, O) 4.4; (N, F) 7.03. The energy differences between the two forms will increase with $\Delta\chi$. The asymmetric isomers are only found in practice for smaller $\Delta\chi$ values.

- (47) Herzberg, G. "Electronic Spectra of Polyatomic Molecules"; Van Nostrand-Reinhold: New York, 1966.
- (48) A more detailed analysis²³ shows that van der Waals molecules have attractive van der Waals interactions and that it is the difference in repulsive terms via the molecular orbital model that accounts for the site preferences. This approach is an extension of the present simple arguments.
- (49) (a) Harris, S. J.; Novick, S. E.; Klemperer, W. *J. Chem. Phys.* **1974**, *61*, 193. (b) Novick, S. E.; Harris, S. J.; Janda, K. C.; Klemperer, W. *Can. J. Phys.* **1975**, *53*, 2007.
- (50) Andrews, L.; Downs, A. J.; Drury, D. J.; Hawkins, M., to be submitted for publication.
- (51) From results of reactions in crossed molecular beams come other indications of the importance of the charge distributions of 9. Reaction of O atoms with ICl leads to the generation of IO and the absence of any detectable ClO in the products. This result is taken to imply that the oxygen atom attacks the iodine end of the ICl molecule (Sibener, S. J. Ph.D. Thesis, University of California, Berkeley, 1979).
- (52) A recent MNDO calculation gives $ClOCl$ more stable than $ClClO$ by ~ 40 kcal/mol but around 110 kcal/mol for the corresponding fluorides: DeKock, R. L.; Jasperse, C. P.; Dao, D. T.; Bieda, J. H.; Liebman, J. F. *J. Fluorine Chem.* **1982**, *22*, 575.
- (53) (a) Tevault, D.; Walker, N.; Smardzewski, R. R.; Fox, W. B. *J. Phys. Chem.* **1978**, *82*, 2733. (b) Campbell, C.; Jones, J. P. M.; Turner, J. *J. Chem. Commun.* **1968**, 888. (c) Allen, S. D. Ph.D. Thesis, University of Nottingham, 1983.
- (54) Wei, M. S.; Current, J. H.; Gendell, J. *J. Chem. Phys.* **1972**, *57*, 2431.
- (55) Burdett, J. K.; Current, J. H., unpublished infrared results.
- (56) Peake, S. C.; Downs, A. J. *J. Chem. Soc., Dalton Trans.* **1974**, 859.

Site reversals are also found in series of stable molecules. The nitrosyl halides have the structure XNO whereas the thiazyl halides are found⁵⁰ as XSN . The general results also carry over to polyatomic molecules. SOF_2 contains²¹ three-coordinate sulfur rather than three-coordinate oxygen. In the area of cage molecules, As_4S_4 , S_4N_4 , and Se_4N_4 are based⁵⁷ on structure 12 containing two- and three-coordinate sites. In As_4S_4 the more electronegative sulfur atoms and in $S(e)_4N_4$ the more electronegative nitrogen atoms occupy the two-coordinate sites.

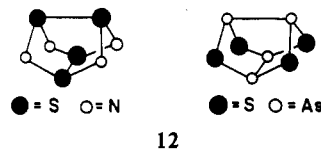

Thus, the three-center model is quite successful at predicting site preferences. Is it as successful at unravelling more detailed structural parameters?

Bond Lengths and the Three-Center Model

In this section we start with the three-center bonding model for A_3 (vide supra) and see how it is modified for A_2X . Given that the most electronegative atom X will in general preferentially reside at a terminal site of an A_2X molecule, it is interesting to inquire how the strength of the AX and AA linkages, measured qualitatively by either interatomic distance or vibrational force constant,⁵⁸ depends upon the nature of X. This is a difficult problem to tackle numerically. We have already noted the problems encountered when theoretical methods, much better than ours, are used in the area of fluorine compounds and peroxides.^{24,26} Perturbation theory,^{35,59} however reveals two competing effects at the simplest level and puts the problem in perspective. First, we will assume that the AB bond length, force constant, or whatever experimental observation we associate with the AB "bond strength"⁵⁸ depends upon the bond overlap population (eq 2) between the

$$Q_{AB} = \sum_k P_{AB} = 2 \sum_k \sum_{ij} c_{ik}(A) c_{jk}(B) S_{ij} N(k) \quad (2)$$

two atoms concerned. Here, we sum the product of the atomic orbital coefficients on atoms A,B in a given molecular orbital k , weighted by their overlap integral S_{ij} and the number N of electrons in this orbital. Simulation of a change in the Mulliken electronegativity of one of the atoms in the usual manner by increasing or decreasing the relevant H_{ii} values leads to no change in first order in Q_{AB} of eq 2. In second order the change in the wave functions induced by this substitution will lead to a change in the coefficients c_{ik} and c_{jk} and hence a change in Q_{AB} . Real atoms however will not only differ in their orbital energies but will also lead to different values of S_{ij} in eq 2 as a result of different interatomic distances and different atomic wave functions. This effect will lead to a direct change in Q_{AB} . We look at these two effects in turn. First, if the electronegativity of one of the end atoms is increased ($A_3 \rightarrow A_2X$) by increasing the size of the relevant Coulomb integrals, H_{ii} on that atom, but keeping the overlap integrals constant, we know that the coefficient of this atomic orbital in the deepest lying molecular orbital of the three-center

- (57) (a) Lu, C.-S.; Donohue, J. *J. Am. Chem. Soc.* **1944**, *66*, 818. (b) Turner, A. B.; Mortimer, F. S. *Inorg. Chem.* **1966**, *5*, 906. (c) Bärnighausen, H.; Volkman, H.; Jander, J. *Acta Crystallogr.* **1966**, *21*, 571. (d) There is also an interesting alternative orbital derivation of this result: Gleiter, R. *Angew. Chem.* **1981**.
- (58) Caution should be exercised when bond lengths and force constants are compared in molecules, especially those of different atomicity. For the XNO species of Table I, for example, note the different trends in NO bond lengths and vibrational force constants when compared to those of free NO .
- (59) Hoffmann, R. *Acc. Chem. Res.* **1972**, *4*, 1.

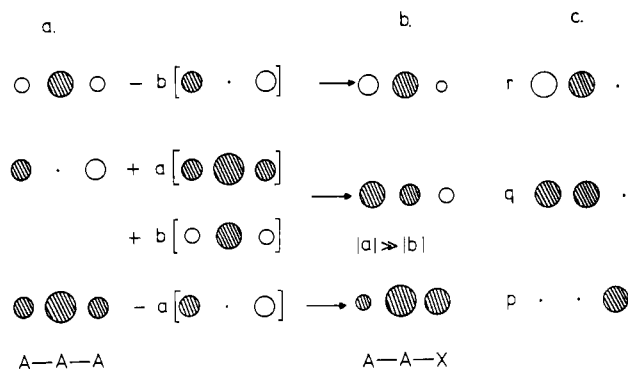

Figure 2. Change in nature of the orbitals of the three-center A_3 system (a) when the VSIP of a terminal atom orbital is increased (b). The extreme case when the X-located orbital lies very deep in energy is also shown (c). a and b are the c_{ij} coefficients of eq 3. Only the dominant mixing is shown. There is a small mixing of orbitals p and r .

set must increase. Taken to the extreme limit, a very deep-lying orbital will interact very poorly with the rest of the molecule and will be largely located on a single atom. How in detail the situation changes as this substitution is made is most easily seen by using simple perturbation theory.⁵⁹ We start with A_3 . The energy levels for three $p\sigma$ orbitals are shown in Figure 1b. The level pattern for three $p\pi$ orbitals (allyl problem) or three s orbitals is very similar. These are shown at the left side of Figure 2. Starting with the deepest lying orbital they are labeled p , q , and r . As a result of the perturbation, the new wave functions φ'_p , φ'_q , and φ'_r may be described as a linear combination of the old as

$$\varphi'_i = \varphi_i + \sum c_{ij}\varphi_j \quad (3)$$

where the mixing coefficient c_{ij} is simply given by⁵⁹

$$c_{ij} = \frac{\langle \varphi_i | H_{\text{pert}} | \varphi_j \rangle}{E_i - E_j} \quad (4)$$

The denominator is just the unperturbed energy level separation. In fact, we do not need to evaluate the c_{ij} numerically at all. Just knowing that the level φ_j mixes into those below it in a bonding fashion and into levels above it in an antibonding fashion via the energy denominator in eq 4 is sufficient for our needs. Figure 2b shows pictorially how this occurs to give the new set of perturbed orbitals. Finally in Figure 2c we show the extreme case where the perturbation is so great that there is no interaction between X and A_2 . A result, central to our discussion below, is that the middle orbital of the trio (orbital q), nonbonding in A_3 , becomes AA bonding ($A-A$) but AX antibonding ($A+X$), and increasingly so, as the electronegativity of X increases in A_2X . Analogously, decreasing H_{ii} for the terminal atomic orbital leads to an orbital q that is $A+A$ but $A-X$. This is illustrated in Figure 3.

Second, we examine the case where the overlap integral between A- and X-located orbitals is increased or decreased. Figure 4 shows the effect of decreasing the AX interaction while keeping H_{ii} constant. Eventually, if the overlap goes to zero, the top and bottom orbitals of the trio become respectively the antibonding and bonding orbitals of the A_2 diatomic and the middle orbital is completely X located. This simple result helps us understand how the unperturbed orbitals of A_3 will mix to give those of A_2X as a result of changing the AX overlaps. Note that the contribution to the AX bond overlap population in the bottom orbital of the set has clearly decreased as a result of the perturbation. Thus, if the increase in electronegativity $A \rightarrow X$ is associated with a decrease in relevant AX overlap integrals, then a species with the electronic configuration p^2q^2 will have a weaker AX than AA linkage. If

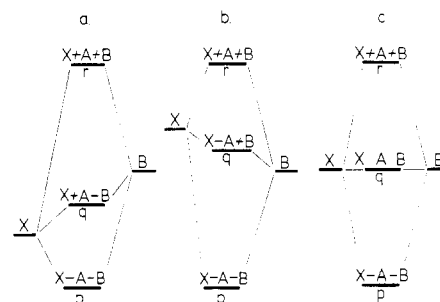

Figure 3. Bonding properties of the three-center orbitals (p , q , r) as the VSIP of the X-located orbital is changed between atoms X and A: X-A, bonding; X+A, antibonding; X A, nonbonding.

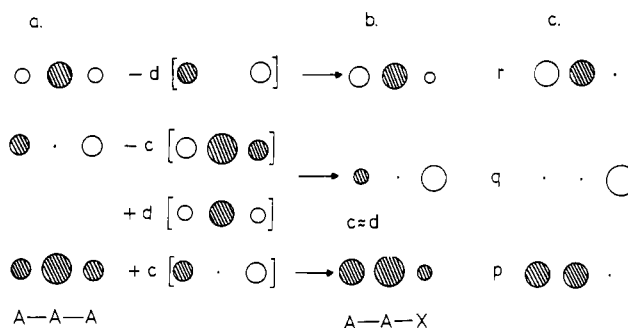

Figure 4. Change in the nature of the orbitals of the three-center A_3 system (a) when the AX overlap integral is decreased (b). The extreme case where there is no interaction between X and A_2 is also shown (c). c and d are the coefficients c_{ij} of eq 3. Only the dominant mixing is shown. There is a small mixing between orbitals p and r .

the two effects work in opposite directions (i.e., if increasing the electronegativity of X results in an increase in AX overlaps), then it will be very difficult to predict a priori the geometrical details. A further complication occurs here, since if A and X come from different rows of the periodic table, then grossly different AA and AX distances are to be expected from simple size considerations, with extra ambiguities as to the direction of this effect. What is of course possible and what we will see later is an atom X with smaller $|H_{ii}|$ values than A but which in XAA gives rise to a strong AA linkage.

We may use simple arguments based on the results of Figures 2 and 4 to view the XAB and A_2X_2 problem in a little more detail.

Very Electronegative Atoms X

This particular case is best illustrated by viewing bent FAB molecules. For bent XAB species, in general, we will be interested in the interaction of a p orbital on X (s orbital for $X = H$) with the $p\pi$ orbitals of the AB diatomic that lie in the same plane (13). This will serve as a simplified model

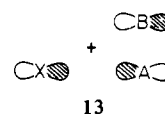

of these systems and has virtues in being such. It also allows a direct comparison with the ideas of the $(p-\pi^*)\sigma$ model of JLSP. We assume that this interaction is the dominant interaction present between X and AB. Out-of-plane interactions will be considerably smaller on overlap grounds, and if the overall interaction is weak, then the $p\sigma$ orbital of the AB unit should be little affected. The bonding characteristics of the three new molecular orbitals (14) formed in such a process are readily visualized by using the preceding arguments. For a very electronegative atom X compared to B (fluorine for example), both of the factors illustrated in Figures 2 and 4 lead to the bonding situation shown in Figure 3a. The lowest

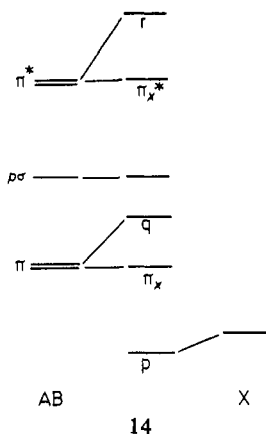

14

orbital (p) is bonding between both AB and AX (X-A-B), the middle orbital (q) is bonding between A and B but antibonding between A and X (X+A-B), and the uppermost (r) is antibonding throughout (X+A+B). In FOO, there are four electrons to fill this group of orbitals and this leads to the configuration $p^2(\pi_x)^2(p\sigma)^2q^2(\pi_x^*)^1$ (14). Since orbital q is A+X, it cancels some of the AX bonding contributed by orbital p. Similarly since q is A-B, the bonding between the oxygen atoms will be reinforced. Hence, we predict strong OO and weak OF bonds as actually found for both O_2F and O_2F_2 . The latter we consider to be composed of two orthogonal systems 13.

In FNO, which differs from the above by one electron, the configuration is simply $p^2(\pi_x)^2(p\sigma)^2q^2$ and the situation is very similar to that in FOO. In this case, there are additional electronic spectroscopic results that lend support to our scheme. There lies an excited electronic state of FNO with the orbital configuration $p^2(\pi_x)^2(p\sigma)^2q^1(\pi_x^*)^1$ (14). From the properties of the orbitals q and π_x^* this should have a stronger NF bond but weaker NO bond than found for the electronic ground state. This is precisely what was observed experimentally by Johnston and Bertin.⁶⁰ Comment on the structural parameters of such excited states is clearly not possible by using the valence-bond or JLSP schemes. In $Ar\cdots N_2$, which is isoelectronic with FNO, the ground-state angular geometry appears similar and, in accord with the large electronegativity of argon compared to that of nitrogen, the $Ar\cdots N$ distance is long and the NN distance short and very similar to that in N_2 itself. Thus, again the AX distance is "unusually long" and the AB distance "unusually short" in this species if we employ the same language used above for more conventional molecules.

FNO has one electron less than FOO, and in the latter the extra electron lies in an OO π^* orbital perpendicular to the three-center orbital system. The NO bond in FNO should therefore be stronger than the OO bond in FOO just as the bond in NO is stronger than the OO bond in O_2 itself, as is observed. Also the NF and OF linkages should be of similar strengths. To get to FCO from FNO however, it is now necessary to remove one electron from orbital q of the three-center scheme, an orbital that is F+A-B. This strengthens the AF bond and weakens the AB bond. So whereas the AF and AB bonds in FNO and FOO are unusually weak and strong, respectively, the bonds in FCO should be more nearly normal as is apparent from the data of Table I. These qualitative ideas find support in the results of numerical calculations that we describe in the Appendix.

So we have shown how an AF bond weakening is expected in these molecules with certain electronic configurations by looking at the underlying orbital structure of the undistorted molecules. We now examine how the picture changes with a change in X atom electronegativity.

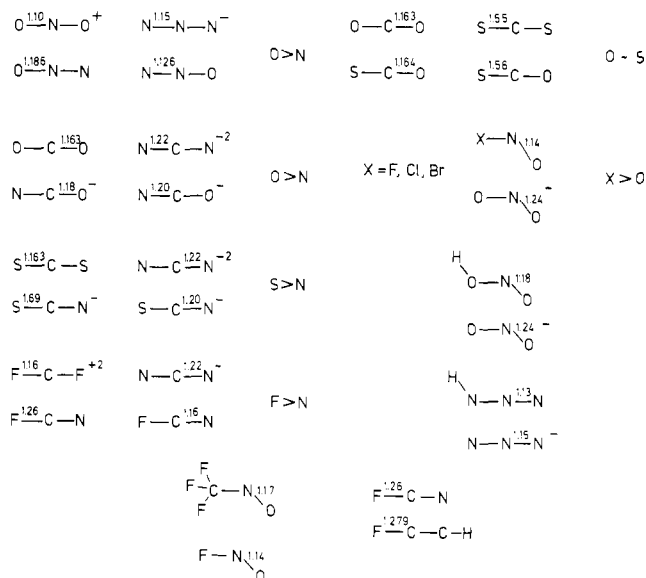

Figure 5. Bond length changes in pairs of isoelectronic molecules as a means of deriving a bond length weakening series. The figures are mostly self-explanatory with the exception of those for the presently unknown species CF_2^{2+} . Geometrical data are available only for the 18-electron bent neutral CF_2 molecule. We know however that the NO distances in NO_2^- , NO_2 , and NO_2^+ are respectively 1.10, 1.197, and 1.24 Å and have used this data to estimate a CF distance in the 16-electron species CF_2^{2+} . The result is a very short distance indeed. A somewhat longer one is seen in FCN, but even so the observed distance in this molecule is shorter than a normal CF single bond.

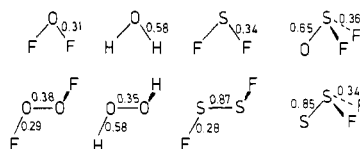

Figure 6. Bond overlap populations in some molecules of interest calculated by using the extended Hückel model. In order to make comparisons meaningful, equal AB distances were used wherever the AB linkage is found; i.e., the same SF distance is used in OSF_2 , SF_2 , and S_2F_2 .

Less Electronegative Atoms X

From Figure 3 we see that, ignoring overlap integral differences, when X is more electropositive than B, the AX bond will strengthen and the AB bond weaken. This clearly happens (Table I) in HOO and HNO when comparison is made to their fluorine analogues. However, difficulties arise when considering ClOO or BrOO and ClNO or BrNO since simple H_{ii} arguments would suggest a steady change from F to H through Cl and Br. In fact, FNO, ClNO, and BrNO on the one hand and FOO, ClOO, and BrOO on the other are very similar. On the present model this problem occurs because of overlap differences when considering atoms from different rows of the periodic table; i.e., the results of Figures 2 and 4 may work in opposite directions as regards the AX and AB bond strengths.

Tevault and Smardzewski⁶¹ have modified the JLSP approach for XO_2 by invoking the sometimes unusual behavior for fluorine (for example, the behavior of F_2 in the order of (halogen)₂ bond energies). Pimental and Spratley²⁹ also predicted from thermochemical considerations that Cl_2O_2 would have the weak dimer structure $ClO\cdots OCl$ in contrast to that of O_2F_2 , $F\cdots O=O\cdots F$, a result later verified experimentally.¹⁸ The basis of the prediction lay in the much higher bond energy of ClO compared to that of FO. Similar con-

(60) Johnston, A. S.; Bertin, H. J. *J. Mol. Spectrosc.* **1959**, *3*, 683.

(61) Tevault, D. E.; Smardzewski, R. R. *J. Am. Chem. Soc.* **1978**, *100*, 3955.

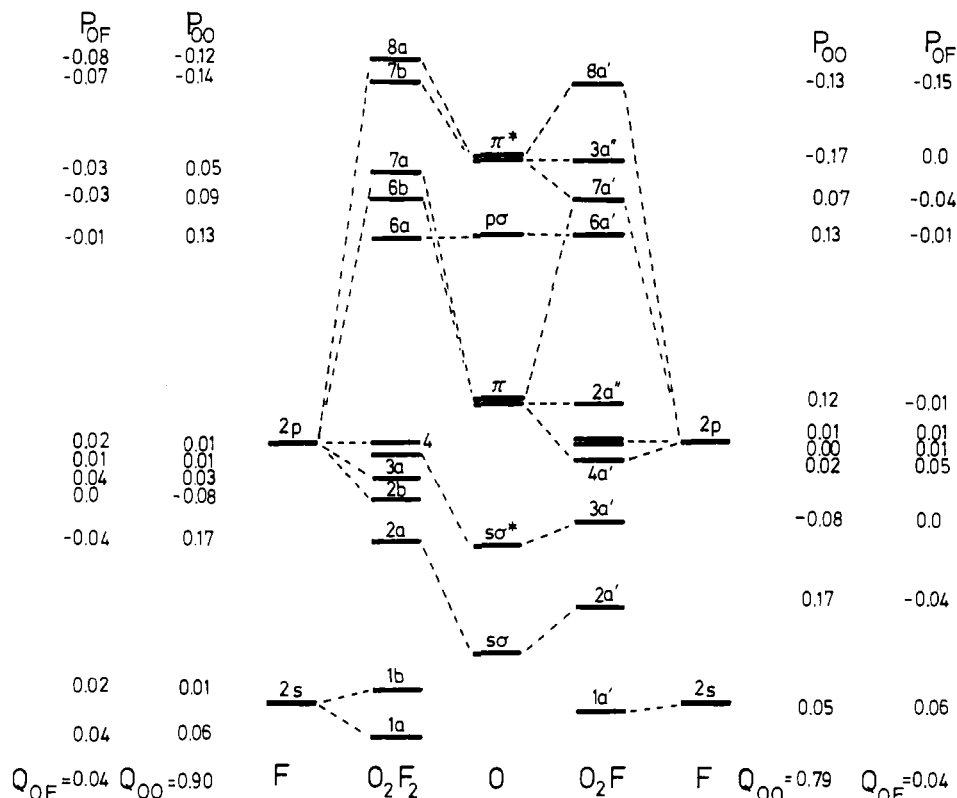
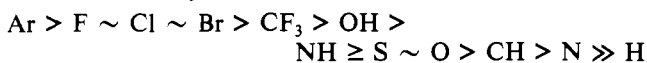

Figure 7. Molecular orbital diagram and orbital population analysis for O_2F by assuming a geometry similar to O_2F_2 and of O_2F_2 itself.

siderations affect the bond strengths in XAB systems too and will be difficult to build into any simple orbital model.

It is clear that there is no simple way to accommodate these two effects simultaneously. However, it is valuable to summarize the structural data from several isoelectronic systems to establish a bond weakening/strengthening series. Figure 5 illustrates some data culled from the literature. From this figure it is clear that, for an ABC system, the effect of A in strengthening the BC bond and commensurately weakening the AB bond may be summarized as⁶²



Obviously, for the elements from a given row of the periodic table, the ordering is that of their standard classical electronegativity, since, with similar interatomic distances, the effects of Figures 2 and 4 probably work in the same direction. The series for one particular row of the periodic table overlaps that for another in a simple sort of way. Note that this series is very different from the trans influence order in Pt(II) complexes, which shows a strong dependence⁶³ on Pauling electronegativity. It is also different from the basicity order of importance in controlling the ease of departure of the leaving group (X) in S_N2 reactions of alkyl compounds CR_3X . Here, the transition-state geometry $Y \cdots CR_3 \cdots X^-$ is isoelectronic with I_3^- . We have also been able to include polyatomic units in this series although here the geometric data for several of the molecules we would like to have for comparison are not available. Interestingly, OH and NH in this series lie to the left of O and N, respectively. This is simply understandable. The frontier orbitals of these fragments will not be completely

localized on the atom (N or O) bound to the AB diatomic, and this will result in a smaller overlap with AB than for the isolated atom. Equivalently and classically, in XH the X atom has less electron density to form strong XA linkages than a free X atom since some density is tied up in the XH linkage.

This series is similar to the one describing secondary coordination in main-group chemistry. In many solid-state structures the coordination environment of a main-group atom contains, in addition to a set of short contacts (bonds), some other longer internuclear contacts shorter than the relevant sum of van der Waals radii.⁶⁴ These contacts are usually trans to a regular bond viz. $Y \cdots AX$. The ordering of the pairs of atoms X,Y from these structural data is in accord with the series too.

Hydrogen lies at one end of the series, and thus HAO systems should correspond to the situation shown in Figure 3b. Indeed, the OH bond in H_2O_2 and HO_2 is⁶⁵ of "normal" length and the OO distance in HO_2 intermediate between that in the oxygen molecule and H_2O_2 . By comparison with the fluoride series above and recognizing the difference in the properties of orbital q, the NH and OH bonds should be of similar strength in HNO and HOO. Since the electron lost on going to HCO comes from orbital q, which is $H-A \lll B$, HCO should have a weak CH bond and a strong CO bond. This is just what is observed experimentally. Milligan and Jacox comment that the CH bond is exceptionally weak and that the CO bond is intermediate between those in formaldehyde and CO itself.^{65c} Olgilvy has suggested⁶⁶ that HCO has the longest CH distance of any ground-state molecule.

An interesting case where the atomic details of the A and X atoms of an A_2X_2 unit are identical occurs in the spiral

(62) (a) The diagram of Figure 5 has used examples containing light atoms from the periodic table. For the polyhalide ions, especially those containing a central iodine atom, very large changes in bond lengths are observed when the nature of the terminal halogen is changed. Including these species would discriminate between the order $Cl > Br > I$. (b) Migchelsen, T.; Vos, A. *Acta Crystallogr.* **1967**, *22*, 812. (c) Carpenter, G. B. *Ibid.* **1966**, *20*, 330.

(63) Hartley, F. R. *Chem. Soc. Rev.* **1973**, *2*, 163.

(64) Alcock, N. W. *Adv. Inorg. Chem. Radiochem.* **1972**, *15*, 1.

(65) (a) Milligan, D. E.; Jacox, M. E. *J. Chem. Phys.* **1963**, *38*, 2627. (b) There is some suggestion^{65a} that HO_2 is somewhat different in nature from H_2O_2 . (c) Milligan, D. E.; Jacox, M. E. *J. Chem. Phys.* **1964**, *41*, 3032.

(66) Olgilvy, J. F. *Spectrochem. Acta, Part A* **1967**, *23A*, 737.

structures of elemental Se and Te and in fibrous sulfur.⁶⁷ The observed structure is made up of infinitely repeating A_4 units with the S_2F_2 or O_2F_2 arrangement. All the AA-bonded distances are equal. Pieces of this structure are also found as polysulfide anions⁶⁸ such as S_4^{2-} , Se_4^{2-} , and polypnictide anions such as As_4^{6-} where the relative AA distances appear to depend on the nature of the cation.

Conclusion

This work has shown that a straightforward delocalized molecular orbital approach is readily able to rationalize the site preferences in these somewhat unusual molecules. Moreover, it is at least as good as other simple models for rationalizing the unusual bond lengths that are frequently found. It has the advantage of using very standard molecular orbital methodology.

Acknowledgment. We are grateful to a reviewer for soothing our worries concerning the discrepancies between the ab initio and semiempirical calculations on systems of this type (see ref 71). The work was supported by grants from the Exxon Foundation and the SERC.

Appendix

Results of Numerical Calculations. The angular structural variations in A_2X_2 systems have been discussed by Gimarc,^{4,69} who showed using simple molecular orbital arguments underwritten by numerical calculations of the extended Hückel type, that the geometry changes in the series C_2F_2 , N_2F_2 , and O_2F_2 are readily understood. Figure 6 shows that numerical calculations of the same type also mimic the observed structural tendencies of Table I. The OF or NF bond overlap population in OF_2 or NF_3 for example is larger than the corresponding population in O_2F_2 or FNO . In these calculations we have kept the OF or NF distances the same. Figure 7 shows the results of some EHMO calculations on O_2F_2 and O_2F using the *observed* geometry. Specific reference is made to the reduced overlap population between atom pairs for each molecular orbital (P_{AB}) and the total bond overlap population (Q_{AB} (eq 2)). Perhaps the most obvious result is that the bonding picture is not as simple as that suggested by JLSP's $(p-\pi^*)\sigma$ bond. If this were the case, we would expect to see little involvement in OF bonding from orbitals not derived from the π^* orbital of the parent diatomic O_2 . This point was noted by Turner and Harcourt,⁷⁰ and it is indeed difficult to imagine, on a simple molecular orbital scheme, a situation where a fluorine p orbital, lying deeper than both π and π^* orbitals of O_2 , can interact solely with the π^* orbital and not with the considerably closer π orbital.⁷¹ From the orbital population

analysis shown in Figure 7 the highest occupied *bonding* orbital between F and O is *not* the orbital formed from an antibonding π^* orbital of O_2 and a p orbital on fluorine as suggested in an earlier extended Hückel study by Loos et al., which was interpreted⁷² in favor of the JLSP scheme. The highest O-F bonding orbital in our one-electron model does in fact lie much deeper.

The general form of the bonding in FOO and O_2F_2 shown in these figures fits the prescription of the three-center scheme very well. (We can use simple perturbation theory to generate these results starting from $O_2 + F$ or $O_2 + 2F$ just as easily of course.) For O_2F for example the p, q, and r orbitals are $4a'$, $7a'$, and $8a'$. The lowest only of the three orbitals from both the out-of-plane and in-plane p-orbital manifolds are OF bonding in O_2F . Thus, the three-center scheme in practice applies to both σ - and π -type interactions. The molecular orbital in O_2F ($6a'$) derived mainly from $p\sigma$ interactions on the oxygen atoms of O_2 does contribute a small amount of OF antibonding character as does its analogue in O_2F_2 ($6a$). It is still predominantly an OO bonding orbital however. It can essentially be neglected when the interaction between fluorine and the oxygen molecule is discussed. The situation is very similar in FNO and FCO .

The negligible contribution to OF (or NF) bonding from the p-orbital manifold is quite apparent. Basically, on this model the fluorine atoms are bound to the AO unit purely by interaction between the 2s orbitals of F and A. For the oxygen case, the total OF overlap population is 0.039 (0.003) and 0.043 (-0.001) in O_2F_2 and O_2F , respectively (with the p-manifold contributions in parentheses). The OF bond in these species is thus indeed quite weak and its description here within the framework of extended Hückel theory strikingly different from that of JLSP. Loos et al. suggest⁷² that the bonding in O_2F is quite different from that in O_2F_2 . The population analysis of Figure 7 however reveals some striking similarities between the molecular orbital schemes for these two molecules. First, as we have just mentioned, the total contribution to OF bonding comes from s-orbital interactions alone in both species. Second, the charges on the fluorine atoms from the population analysis are the same (-0.8 electrons) in both molecules. This is in keeping with the notion that the resonance forms **5** and **6** make an important contribution to the structure of O_2F_2 and its equivalent in O_2F . In H_2O_2 , when the geometric data of ref 10 are used, the hydrogen atomic charge is calculated to be 0.5 and the bond overlap populations (Figure 6) appear quite normal. The OH population is similar to that in H_2O in contrast to a similar comparison for the fluorine analogues. Third, the general form of the eigenvectors is quite similar in O_2F_2 for interactions in the x and y directions (if the OO bond lies along the z axis) as is to be expected for two OF bonds almost at right angles to one another. Both are similar to the form of the molecular orbitals of OOF except that what is regarded as out-of-plane for the F_1OO system is in-plane for the $F_{II}OO$ system. A small increase is calculated in the OO bond overlap population each time a fluorine atom is attached. This is not shown in the vibrational analyses,^{6,7} but the significance of small differences in bond overlap populations and vibrational force constants in molecules of different atomicity is obviously open to debate.

N_2F_2 in this geometry contains two fewer electrons in the pair of q-type orbitals of the three-center system when compared to O_2F_2 . The electronic configuration (Figure 7) is thus $(6b)^2(7a)^0$ and should give rise to stronger AF and weaker AA bonds than for the O_2F_2 system (just like FCO in fact). N_2F_2 is however found in a planar not skew geometry,⁷³ and with

(67) E.g.: Pearson, W. B. "The Crystal Chemistry and Physics of Metals and Alloys"; Wiley: New York, 1972.

(68) (a) See for example: Wells, A. F. "Structural Inorganic Chemistry", 5th ed.; Oxford University Press: New York, 1983. (b) König, T.; Eisenmann, B.; Schäfer, H. Z. Naturforsch., B: Anorg. Chem., Org. Chem. 1983, 37B, 1246.

(69) Gimarc, B. M. J. Am. Chem. Soc. 1970, 92, 266.

(70) Turner, S. J.; Harcourt, R. D. Chem. Commun. 1967, 4, 304.

(71) There is an ab initio molecular orbital calculation for FNO that however finds the HOMO to be NF bonding: Peyrimhoff, S. D.; Buenker, R. J. Theor. Chim. Acta 1967, 9, 103. Presumably this is due to a "floating" upward in energy of the fluorine atomic orbitals as a result of the negative charge on this atom when treated by a "quality" calculational method. A similar feature probably applies to the JLSP approach where its proponents do not place the fluorine p orbital at the very bottom of the interaction diagram but allow it to lie substantially higher in energy so that interaction with the $AB\pi^*$ orbital can be larger than that with the π orbital (Pimentel, G. C., private conversation). How the X atom orbitals are ordered in energy on such an approach is clearly difficult to deduce. The game played in this paper is a very different one and is based on a different set of rules. In our one-electron model, which we choose to use without charge iteration, the fluorine orbitals do not float upward. The two models reach the same conclusions on bond lengths and force constants in these series of molecules. That they fail to agree on intermediate (and importantly nonobservable) results we feel should be no tremendous cause for concern.

(72) Loos, K. R.; Goetschel, C. T.; Campanile, V. A. J. Chem. Phys. 1970, 52, 4418.

no "unusual" bonded distances.

The calculations, which were of the extended Hückel type, have employed the ICON program written by the Hoffmann group.⁷⁴ For calculations on systems such as those of Figure

(73) Note that this distortion is another failure of the second-order Jahn-Teller approach to A_2X_2 geometries: Pearson, R. G. *J. Chem. Phys.* **1970**, *52*, 2167. Since the HOMO and LUMO are of a and b symmetry species, the second-order Jahn-Teller transition should be of b symmetry. It is however an a species distortion (the torsion of N_2F_2) that sends the skew (C_2) structure to either cis or trans planar forms, a point not mentioned in Pearson's paper.

6 and in 19-21, all chemically inequivalent distances were kept equal so as not to bias the results of the population analysis. Standard AX and AA distances were used for molecules such as SF_2 , OF_2 , etc., and the same AX distances were also used therefore for the O_2F_2 , S_2F_2 , etc. molecules in Figure 6. Standard orbital parameters⁵ were used.

Registry No. O_2F_2 , 7783-44-0; O_2F , 15499-23-7.

(74) Howell, J.; Rossi, A. R.; Wallace, D.; Haraki, K.; Hoffmann, R. *QCPE* **1977**, *10*, 344.

(75) Moore, C. E. *Natl. Bur. Stand., [Tech. Rep.] NBSIR (U.S.)* **1970**, *NSRDS-NBS 34*.

Contribution from the Department of Chemistry, Vanderbilt University, Nashville, Tennessee 37235, and J. Heyrovský Institute of Physical Chemistry and Electrochemistry, Czechoslovak Academy of Sciences, 121 38 Prague, Czechoslovakia

Ab Initio Studies on the Ground-State Potential Surface and Vibrational Spectra of NSF and SNF

L. J. SCHAAD,*† B. ANDES HESS, JR.,*† P. ČÁRSKY,† and R. ZAHRADNÍK†

Received January 13, 1984

Theoretical vibrational spectra were calculated for NSF and SNF by the use of the 6-31G* basis. They are sufficiently different to be useful in the identification of the yet unknown SNF. Geometry optimizations were also carried out at the 6-31G*/MP2 level on these two minima and on the transition state connecting them. The activation energy for the conversion of SNF to NSF is predicted to be high enough to allow isolation of SNF at room temperature.

While thiazyl fluoride (NSF)¹⁻⁵ has been known for a number of years, its isomer SNF is unknown. Previous theoretical studies^{6,7} have indicated that SNF does represent a second minimum on the (N, S, F) potential surface. Quite recently the overall potential surface, including the saddle point connecting the two isomers, has been examined at the Hartree-Fock level.⁸ Here we shall describe Hartree-Fock plus correlation (MP2) calculations of the two minima and the transition structure. Theoretical vibrational spectra of the two minima are also presented to aid in the eventual identification of the isomer SNF.

Computational Details

Molecular Orbital Calculations. All calculations described here were done with the standard 6-31G* basis set developed by Pople and his co-workers.⁹ Electron correlation was included by second-order perturbation theory with the Møller-Plesset (MP2) partitioning of the Hamiltonian.¹⁰ The SCF calculations were carried out either with a modified version¹¹ of HONDO 5,¹²⁻¹⁵ in which the BMAT link of Pulay's program TEXAS¹⁶⁻¹⁸ is incorporated for geometry optimization, or with GAUSSIAN 80.¹⁹ MP2 calculations were performed by a program²⁰ written to be used with HONDO 5.

Geometry Optimization. For NSF at the SCF level a set of force constants obtained from the literature^{21,22} was used with the modified HONDO 5.¹¹ The force constants were not kept constant as in the original force method,^{17,18} but they were modified after three cycles because of slow convergence. This was done by using gradients from the three cycles in conjunction with an independent BMAT¹⁶⁻¹⁸ program. An iterative variation of the diagonal force constants was carried out until the three predicted geometries from the three gradients were consistent. The geometry thus obtained from the third-cycle gradient was then used in a fourth energy and gradient calculation, which was taken as the final point since the largest component of the Cartesian gradient was less than 0.001 hartree/bohr. For SNF the optimization

Table I. Calculated Quadratic Force Constants for NSF and SNF^a

const	NSF		SNF	
	6-31G*	6-31G*/MP2	6-31G*	6-31G*/MP2
F_{NS}	12.237	15.886	9.220	6.485
F_{SF}	4.625	3.430		
F_{NF}			5.812	3.835
F_{α}	1.465	1.039	2.035	1.774
$F_{\alpha,NS}$	0.519	0.212	0.505	0.516
$F_{\alpha,SF}$	0.046	-0.206		
$F_{\alpha,NF}$			0.782	0.490
$F_{NS,SF}$	0.630	0.219		
$F_{NS,NF}$			1.294	0.902

^a Stretching force constants are in $\text{mdyn } \text{Å}^{-1}$, bending force constants in $\text{mdyn } \text{Å} \text{ rad}^{-2}$, and stretching-bending interactions in $\text{mdyn } \text{rad}^{-1}$.

procedure in GAUSSIAN 80 was used since no experimental force constants were available.

- Glemser, O.; Schroder, H.; Haesler, H. *Z. Anorg. Allg. Chem.* **1955**, *279*, 28.
- Kirchhoff, W. H.; Wilson, E. B. *J. Am. Chem. Soc.* **1963**, *85*, 1726.
- Cook, R. L.; Kirchhoff, W. H. *J. Chem. Phys.* **1967**, *47*, 4521.
- Richert, H.; Glemser, O. *Z. Anorg. Allg. Chem.* **1961**, *307*, 328.
- Glemser, O.; Mews, R. *Angew. Chem., Int. Ed. Engl.* **1980**, *20*, 883.
- So, S. P.; Richards, W. G. *J. Chem. Soc., Faraday Trans. 2* **1978**, *74*, 1743.
- Collins, M. P. S.; Duke, B. J. *J. Chem. Soc., Dalton Trans.* **1978**, 277.
- Seeger, R.; Seeger, U.; Bartetzko, R.; Gleiter, R. *Inorg. Chem.* **1982**, *21*, 3473.
- Pople, J. S. In "Modern Theoretical Chemistry"; Schaefer, H. F., III, Ed.; Plenum Press: New York, 1977; Vol. 4, pp 1-27.
- Møller, C.; Plesset, M. S. *Phys. Rev.* **1934**, *46*, 618.
- Hess, B. A., Jr.; Schaad, L. J.; Ewig, C. S.; Čársky, P. *J. Comput. Chem.* **1983**, *4*, 53.
- King, J. F.; Dupuis, M. *J. Comput. Phys.* **1976**, *21*, 144.
- Dupuis, M.; Rys, J.; King, H. F. *J. Chem. Phys.* **1976**, *65*, 11.
- Dupuis, M.; King, H. F. *Int. J. Quantum Chem.* **1977**, *11*, 613.

*Vanderbilt University.

†Czechoslovak Academy of Sciences.